

SOLINTEG EBS-B SERIES HIGH VOLTAGE STORAGE SYSTEM

EBS-S5K1-B,EBS-S7K5-,EBS-S10K-B
EBS-S12K-B,EBS-S15K-B,EBS-S17K-B
EBS-S20K-B,EBS-S23K-B,EBS-S25K-B

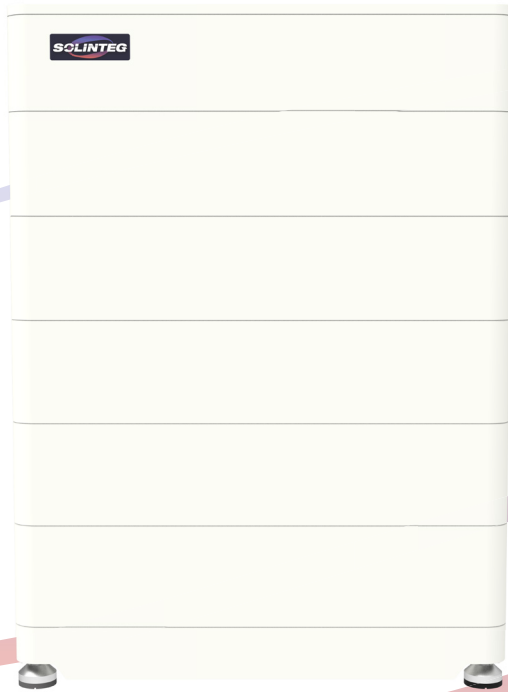

User Manual

ENGLISH VERSION









As an indispensable part of Solinteg EBS-B series storage system, this manual introduces the assembly, installation, electrical connection, communication connection, maintenance and troubleshooting of the products.

This document serves only as a guide, wherein only the basic requirements are listed, to use. All statements, information and recommendations in this document do not constitute any express or implied guarantee.

All operations, such as transportation, storage, installation, operation, use, and maintenance, should comply with applicable laws, regulations, standards, and normative requirements.

The products, services or features purchased are subject to the commercial contracts and terms of Solinteg Power Co., Ltd. All or part of the products, services or features described in this document may not be within the scope of purchase.

	ATTENTION: The battery could explode and/or be severely damaged if dropped or crushed.
	ATTENTION: Appropriate mechanical lifting equipment must be used.
	ATTENTION: The battery may explode if exposed to open flames or other extreme sources of heat.
	ATTENTION: The battery terminals must be disconnected before commencing any work on the battery.
	ATTENTION: Do not touch the B+ or B- terminals for accumulate parasite current. Always check the B+ and B- terminals with a voltmeter. Do not connect or charge the single module directly from the two terminals. The Battery module CANNOT be connected in parallel directly.
	ATTENTION: Always wear Individual protection devices, use insulated tools, and follow the safety plan of this manual.
	ATTENTION: Always wear Individual protection devices, use insulated tools, and follow the safety plan of this manual.

CONTENTS

1	Safety Instructions	6
	1.1 Environment Requirements	6
	1.2 Safety Guidelines	6
	1.3 Personnel Requirements.....	7
	1.4 Precautionary Statement and Response.....	7
	1.4.1 Battery Leakage	7
	1.4.2 Fire	8
	1.5 Hazard Statement	8
	1.6 Statement	9
2	Product Introduction	10
	2.1 Appearance Introduction	10
	2.1.1 Controller Module.....	10
	2.1.2 Battery Module	11
	2.1.3 Base Module	11
	2.1.4 Paraller	12
	2.2 Indicator	13
	2.3 Packing List	13
3	Installation	16
	3.1 Installation Requirements	16
	3.2 Location and Mounting	16
	3.2.1 Base Location	16
	3.2.2 Controller and Battery Modules Mounting	17
	3.2.3 Paraller Mounting	21
	3.2.4 Ground Connection	22
4	Connection with MHS/MHT Series	24
	4.1 Single Battery Cluster	24
	4.1.1 Electrical Wiring Diagram	24
	4.1.2 Power Cable Connection.....	24
	4.1.3 Communication Cable Connection	26
	4.2 Multiple Battery Clusters with Paraller.....	27
	4.2.1 Electrical Wiring Diagram	27
	4.2.2 Power Cable Connection.....	27
	4.2.3 Communication Cable Connection	31
5	Commissioning	33
	5.1 Switch Battery On	33
	5.2 Switch Battery Off	33

CONTENTS

6	Maintenance and Troubleshooting	34
6.1	Maintenance	34
6.2	Troubleshooting	36
7	Appendix.....	37
7.1	Technical Parameters	37
7.1.1	Components of EBS-B Storage System	37
7.1.2	Energy Storage System	39
7.2	Contact Information	42

1 Safety Instruction

1.1 Environment Requirements

This product is designed for indoor operation. It must be installed in a location complying with following:

- Temperature: -10~55°C
- Storage temperature: 0~45°C
- Relative humidity: 5% ~ 95%RH
- Ground shall be flat and level.
- With no direct-sun exposure, metal scurf, dust or corrosive gas.
- With suitable ventilation.
- With no liquid, flammable or explosive material in the installation area.
- Out of reach of children or pets.
- Must equipped with fire-extinguisher system.

1.2 Safety Guidelines

- Only can be installed and operated by **authorized and qualified** personnel.
- Adequately **insulated tools** must be used at all times to ensure battery terminals are not short-circuited.

(as defined by ASTM F1505 / IEC 60900:2012 “Standard Specification for Insulated and Insulating Hand Tools”)

- The safety guidelines included in this document may not include or consider all the regulations in your area of installation/operation. When installing and operating this product, the installer must review and consider applicable **Federal, State, and Local laws and regulations** in accordance with the industry standards of the product.
- **Stable and reliable grounding** shall be equipped properly for safety and normal operation.
- Please carefully check the products before installation. Please contact us immediately if any abnormal damage or deformation, especially stab, hit, trample or strike.
- **Protective equipment** must be used during installation, disassembly and operation, such as protective clothing, insulated shoes, goggles, safety helmets, insulated gloves, etc.
- Please **do not mix use** batteries from different manufacturers, different types and models, as well as old and new together.
- **Prohibited** to install, disassemble or operate any part of the whole system if any part is **electrified** during normal.
- Prohibited to drill, cut, chop, puncture, deform, incinerate or any other destructive action, which may lead to damage of sealing, insulation.
- Carefully check and confirm the power connection, communication connection and con-

figuration of whole system (including inverter, battery, PV, load, utility grid, etc.) in accordance with corresponding manual before operation.

- Do not dispose in fire, mix with other battery types, charge above specified rate, connect improperly, or short circuit, which may result in overheating, explosion or leakage of cell contents.
- Do not open or disassemble.
- Keep away from heat/sparks/open flames/hot surfaces.

Ambient and storage method could impact the product life span, so please comply with the operation environment instruction to ensure that device could work in proper condition.

1.3 Personnel Requirements

Personnel capable of product installation, electrical and cable connection, commissioning, maintenance, troubleshooting, and replacement must meet the following requirements:

- Personnel must be trained in installation, commissioning of the electrical system and dealing with hazards.
- Personnel should read this manual thoroughly and understand the safety matters related to operation.
- Personnel should be familiar with the relevant local safety regulations of electrical systems.
- Do not wear metal objects such as rings, watches, and key chains and take proper safety precautions, such as wearing insulation gloves and electrician's shoes.
- Do not store un-insulated tools in pockets or tool belts while working in the vicinity of the battery to avoid short circuits and personal injuries.

1.4 Precautionary Statement and Response

▼ 1.4.1 Safety Protection Measures

Due to the corrosion of electrolyte, protective gloves /protective clothing / eye protection / face protection shall be used to avoid directly contact. If exposed to the leaking substance, following actions shall be taken:

People shall be evacuated and get medical attention immediately.

- If inhalation: Contaminated work clothing must not be allowed out of the workplace. And completely washed before reuse.
- If skin contact: Wash with plenty of water and get medical advice/attention immediately.
- If eye contact: Rinse cautiously with water for several minutes. Remove contact lenses, if present and easy to do. Continue rinsing. And then get medical advice/attention.
- If ingestion: Induce vomiting and get medical advice/attention immediately.

▼ 1.4.2 Fire

- Carbon dioxide, Novac1230, or FM-200 fire extinguishers shall be equipped near the equipment.
- Extinguish the fire before battery catching fire.
- If battery on fire, evacuate people immediately without any hesitation.

1.5 Hazard Statement



This product is a "Hazardous Chemical" as defined by the OSHA Hazard Communication Standard. Additional information is given in the Safety Data Sheet.

Dispose of contents/container in accordance with local/regional/national/international regulations.

The materials contained in this product may only represent a hazard if the integrity of the cell or battery is compromised and/or physically, thermally, or electrically abused. Anticipated hazards under those conditions as below:

- skin irritation,
- serious eye irritation,
- allergic skin reaction,
- damage to organs (bone, teeth) through prolonged or repeated exposure.
- Toxic to aquatic life.
- Harmful to aquatic life with long-lasting.
- Warning Statements

Lithium Iron Phosphate (LiFEP04) Battery or Cell DANGER

	Warning hazard sign
	Health hazard
	It is very toxic to aquatic life

1.6 Statement

Solinteg Power Co., Ltd. has the right not to undertake quality assurance in any of the following circumstances:

- ① Damages caused by improper transportation.
- ② Damages caused by incorrect storage, installation or use.
- ③ Damages caused by installation and use of equipment by non-professionals or untrained personnel.
- ④ Damages caused by failure to comply with the instructions and safety warnings in this document.
- ⑤ Damages of running in an environment that does not meet the requirements stated in this document.
- ⑥ Damages caused by operation beyond the parameters specified in applicable technical specifications.
- ⑦ Damages caused by unauthorized disassembly, alteration of products or modification of software codes.
- ⑧ Damages caused by abnormal natural environment (force majeure, such as lightning, earthquake, fire, storm, etc.).
- ⑨ Any damages caused by the process of installation and operation which don't follow the local standards and regulations.
- ⑩ Products beyond the warranty period.

2 Product Introduction

2.1 Appearance Introduction

▼ 2.1.1 Controller Module

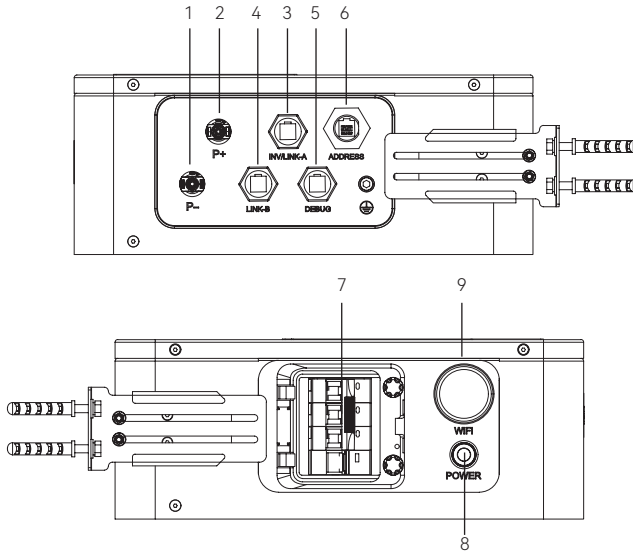

The definition and description of controller's ports are shown as below:

Item	Terminal	Note
1	P-	Battery negative socket
2	P+	Battery positive socket
3	LINKA/INV	Inverter communication connection port Battery parallel connection port
4	LINKB	Battery parallel connection port
5	DEBUG	Service port used to upgrade, export data and so on
6	ADDRESS	Set address for each cluster using EBS-P (Paraller)
7	BREAKER	Prevent battery from over-discharging
8	POWER/ALARM	Switch on/off the battery. Status of indicator can define the status of the battery cluster.
9	WIFI	Wifi module integrated

▼ 2.1.2 Battery Module

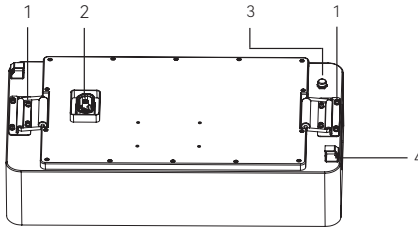

Top View of Battery Module

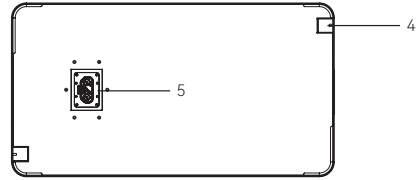

Bottom View of Battery Module

Item	Terminal	Note
1	Lifting Handle	/
2	Input of Power Supply Terminal	/
3	Decompression Valves	/
4	Stack Battery Slot	/
5	Output of Power Supply Terminal	/

▼ 2.1.3 Base Module

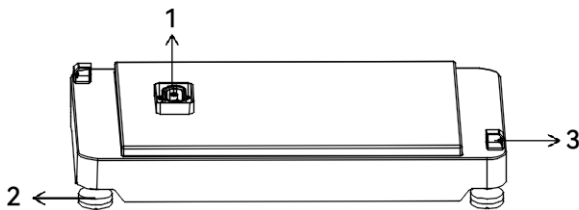

Item	Terminal	Note
1	Power Supply Terminal	/
2	Adjustable Foot Cup	/
3	Stack Battery Slot	/

▼ 2.1.4 Paraller

Paraller is only needed when multiple battery clusters are parallel connected, and it supports at most 3 battery clusters.

If only 1 battery cluster is equipped in the system, please skip this part.

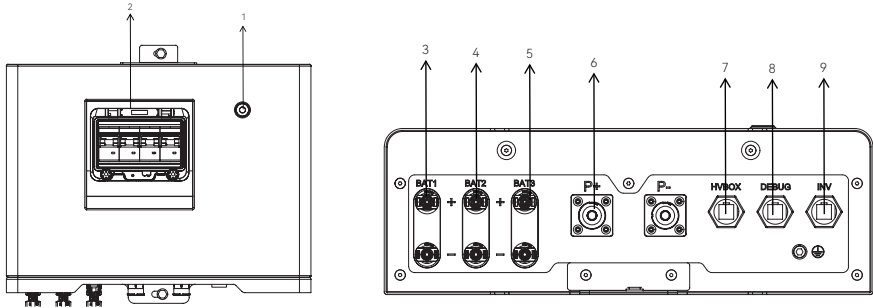

No.	Definition	Description
1	POWER/ALARM	Switch on/off the battery. Status of indicator can define the status of the battery cluster.
2	BREAKER	Switch on/off the parallel-connected battery system
3	BAT1	Input of power supply connected to 1st battery cluster
	+	
	-	
4	BAT2	Input of power supply connected to 2nd battery cluster
	+	
	-	
5	BAT3	Input of power supply connected to 3rd battery cluster
	+	
	-	
6	P+	Output of power supply connected to the inverter
	P-	
7	HVBOX	Communication port connected to battery cluster
8	DEBUG	Service port used to upgrade, export data and so on
9	INV	Communication port connected to the inverter

2.2 Indicator

The status of power indicator and its corresponding explanation are shown as below:

No.	Indicator Status	Description
1	Off	The battery is powered off.
2	Flash green and red lights alternately	The breaker is switched on, and the battery is waiting for entering self-checking.
3	Green color is always on.	Working normally or under debugging
4	Green color is flashing.	Under self-checking
5	Red color is always on.	The battery is under alarm or protection. *Under parallel system, when the breaker of one battery cluster trips, and the rest are running normally or under debugging, the indicator of EBS-P will be on and red.
6	Red color is flashing.	The battery is under fault, which needs human intervention.

2.3 Packing List

The package of the battery includes the following accessories. Please check whether the accessories in the packing box are complete when receiving the goods.

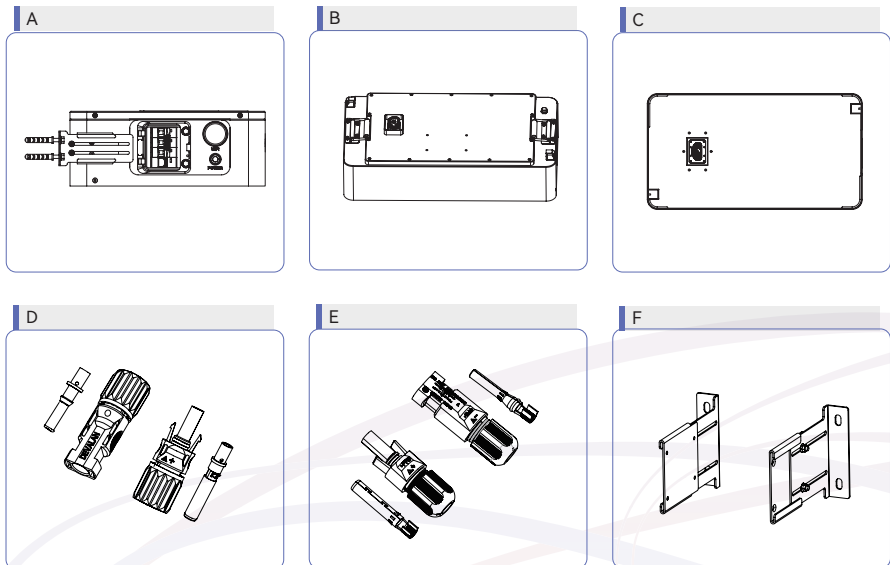

G

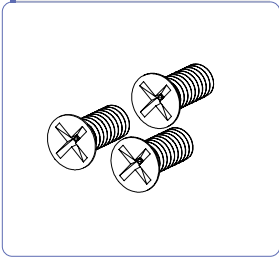

H

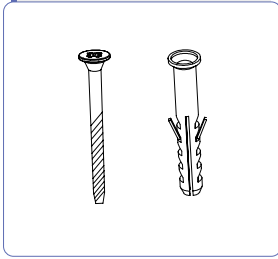

I

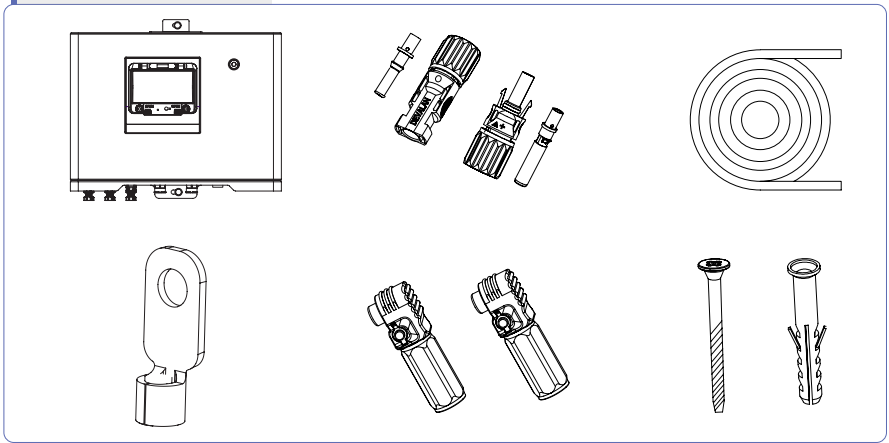

No.	Item	Quantity	Remark
A	Controller Module(EBS-C)	1	With PE terminal and its screw
B	Battery Module(EBS-B2K5-B)	2~10	Based on one battery cluster
C	Base Module(EBS-A)	1	/
D	Battery Terminal	1 pcs	/
E	RJ45 Waterproof Connector	3	/
F	Controller Module Mounts	2	Stabilize controller module
G	M4*8 Countersunk Screw	6	Fix controller module mounts on controller
	M4*12 Countersunk Screw	2	Stack controller module on battery module
	M4*12 Countersunk Screw	2	Fix stacked battery modules Based on one battery module
H	M6*60 Expansion Screw	4	Fix controller module mounts to the wall
I	Paraller and Its Accessories (Optional)	1 pcs	Paraller*1 Battery terminal*3 pcs controller communication cable 2m*3 PE terminal*2 150A battery terminal*1 pcs(orange and black) M6*60 expansion screw*2

3 Installation

3.1 Installation Requirements

- ① The area is completely water proof. The floor is flat and level.
- ② There are no flammable or explosive materials.
- ③ The ambient temperature is within the range from 0 to 50°C .
- ④ The temperature and humidity are maintained at a constant level. There is minimal dust and dirt in the area.
- ⑤ The distance from heat source is more than 2 meters.
- ⑥ Do not place the battery at children or pet touchable area. The installation area shall avoid direct sunlight.
- ⑦ There are no mandatory ventilation requirements for battery module, but please avoid installation in confined area (minimum 300mm to top/left/right/front).
- ⑧ The aeration shall avoid of high salinity, humidity, or temperature.

3.2 Location and Mounting

▼ 3.2.1 Base Location

- ① Check the installation environment to ensure ground level. Place the base on the ground, and make sure it is level and stable by adjusting foot cups.

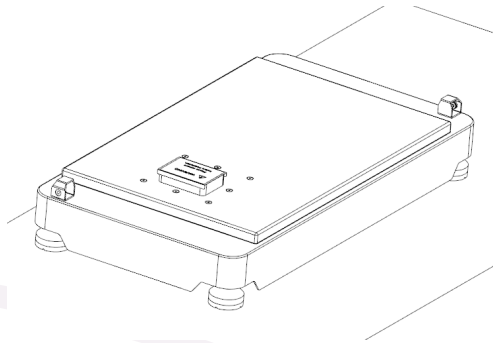

- ② Distance between base and wall is 20mm~120mm.

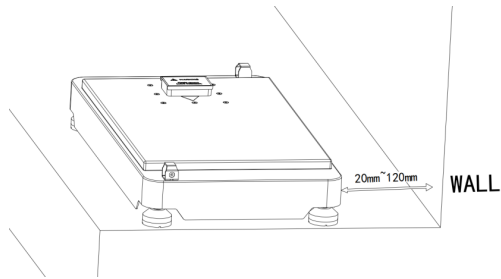

③ Remove dust-proof label on power supply terminal.

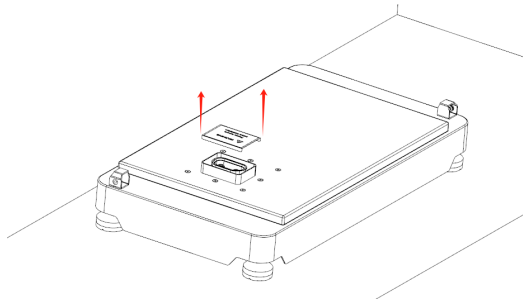

▼ 3.2.2 Controller and Battery Modules Mounting

① Remove dust-proof label on power supply terminal.

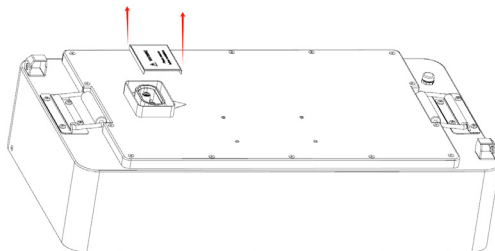

② Place the battery modules on the base one by one slightly, and please note that the power supply terminals of all battery modules and base should be at the same side.

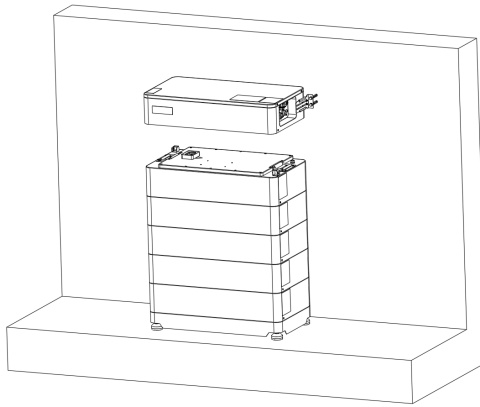

③ Install controller module mounts on both sides of controller module.

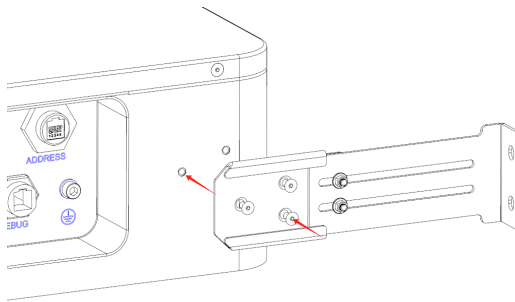

④ Mark the position of 4 holes to be drilled on the wall.

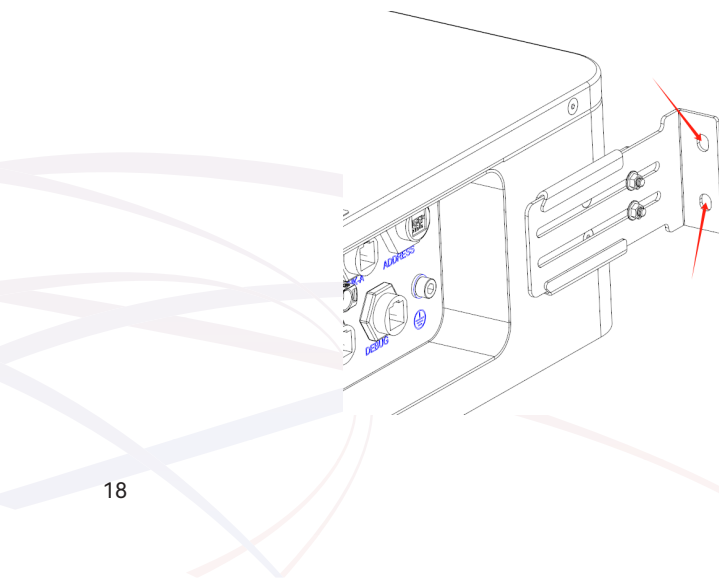

- ⑤ Remove controller module.

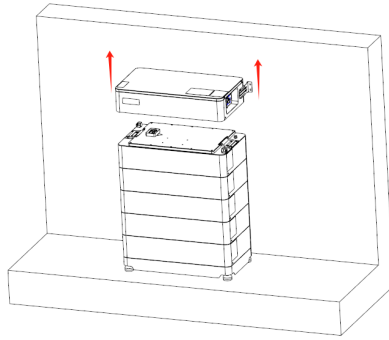

- ⑥ Use a $\Phi 8$ drill bit for the wall hole 80mm deep, and put expansion tubes into them.

Hole depth:80mm

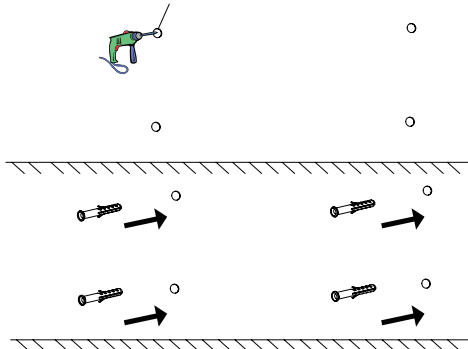

Before drilling, be sure to avoid water pipes and wires buried in the wall.

- ⑦ Place controller module on battery modules.

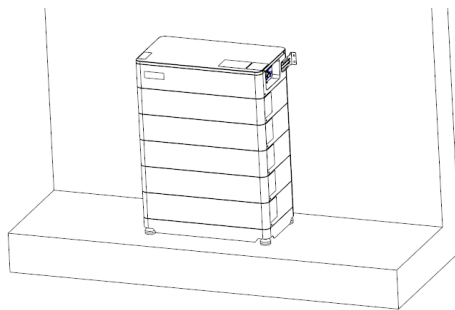

- ⑧ Tighten all M4*12 countersunk screws at both side of all battery modules and controller module.

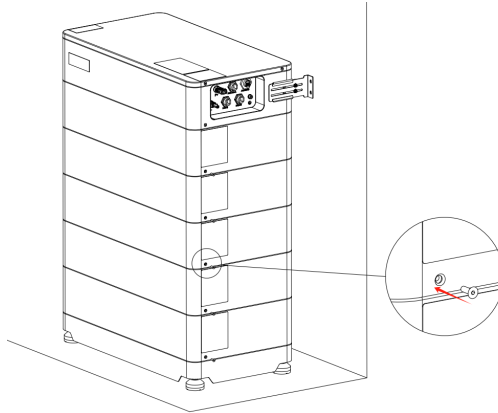

- ⑨ Insert the expansion screws into the tubes, then fix the mounts onto the wall with expansion screws by using a cross screwdriver.

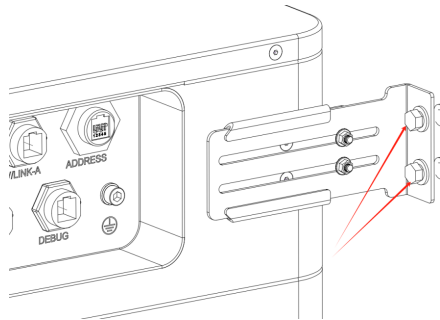

- ⑩ Turn the adjusting screws to fix the battery onto the wall by using a wrench.

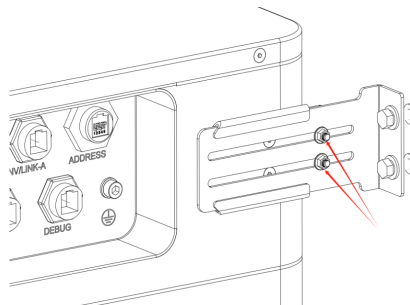

▼ 3.2.3 Paraller Mounting

① According to the location of battery cluster, select a proper location for paraller.

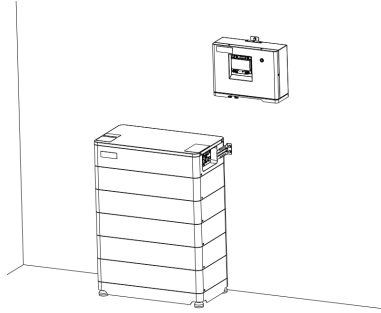

② Mark the position of 2 holes to be drilled on the wall.

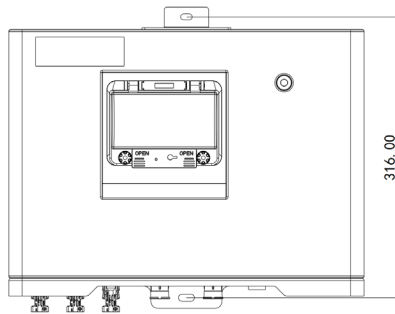

③ Use a $\Phi 8$ drill bit for the wall hole 80mm deep, and put expansion tubes into them.

Depth:80mm

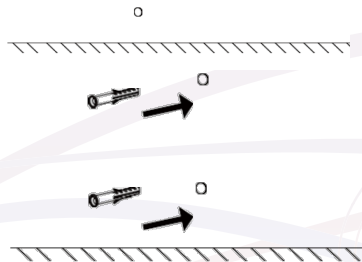



1. Before drilling, be sure to avoid water pipes and wires buried in the wall.
2. Due to the risk of falling and injury, the paraller requires 2 people to install.

④ Insert the expansion screws into the tubes, then fix the Paraller onto the wall with expansion screws by using a cross screwdriver.

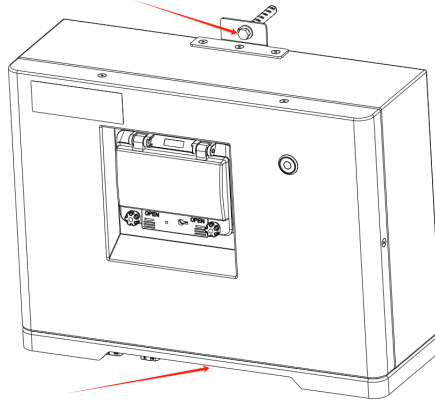

▼ 3.2.4 Ground Connection



Proper grounding is good for resisting surge voltage shock and improving EMI performance. Battery must be well-grounded.

For a system with only one battery cluster, the PE cable needs to be grounded. For a multi-battery paralleling system, the PE cables and all battery clusters need to be connected to the same grounding copper bar to ensure equipotential bonding.

Grounding Steps of Controller:

- ① The external grounding port is located at the right side of controller module.
- ② Fix the grounding terminal to the PE wire with a proper tool and lock the grounding terminal to the grounding port at the right side of controller module.

- ③ The cross-sectional area of the external grounding cable is 6mm^2 .

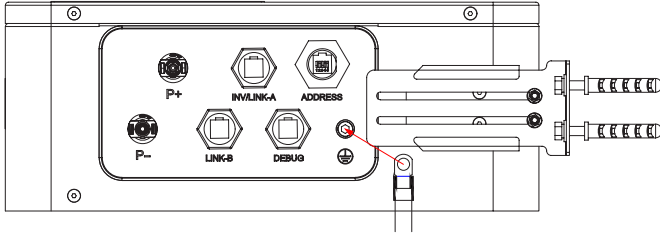

Grounding Steps of Paraller

- ① The external grounding port is located at the bottom of paraller.
- ② Fix the grounding terminal to the PE wire with a proper tool and lock the grounding terminal to the grounding port at the bottom of paraller.
- ③ The cross-sectional area of the external grounding cable is 6mm^2 .

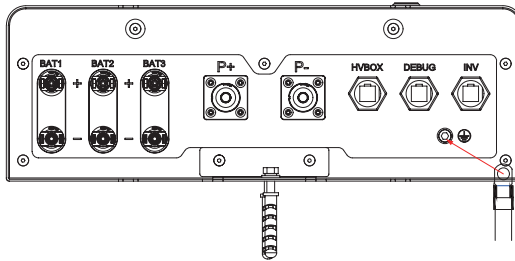

4 Connection with MHS/MHT Series

4.1 Single Battery Cluster

▼ 4.1.1 Electrical Wiring Diagram

After mechanical installation is finished, please follow the instructions to complete the power cable and communication cable connections.

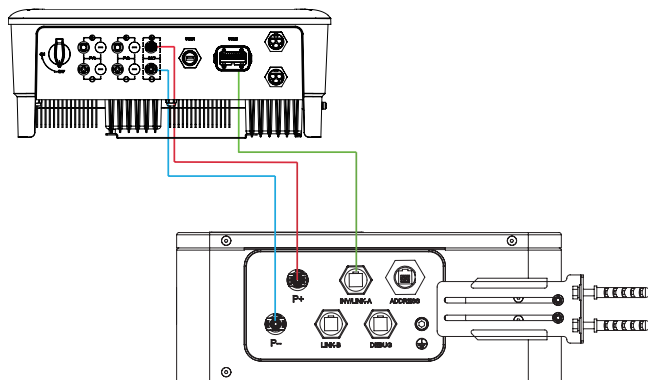

▼ 4.1.2 Power Cable Connection

Before starting connecting the power cable, please obey the following requirements to ensure personal safety:

- ① Turn the AC breaker off on the grid side.
- ② Turn the battery breaker off.
- ③ Switch the inverter DC switch to the “OFF” position.

Power cable connection procedure is shown as below:

1. Select an appropriate DC cable.

Cable requirements		Cable stripping length
Outside diameter	Conductor core section	
5.0-8.0 mm	10 mm ²	10 mm

2. Peel off the battery cable insulation sleeve for 10 mm.

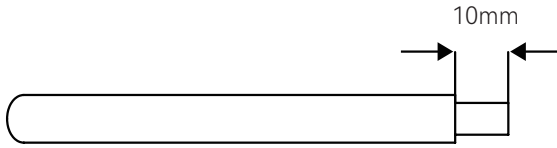

3. Take out the battery terminals in the accessory bag.

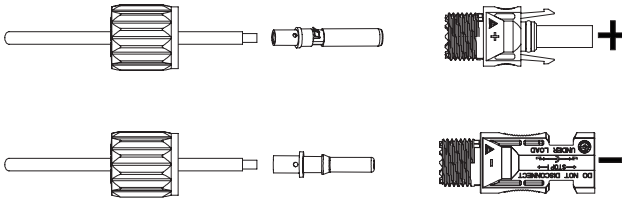

4. Insert the positive and negative cables into the corresponding connectors, and then press the terminal with crimping pliers. After assembling, try to pull back the battery cable to ensure that the terminal is tightly attached in the connector.

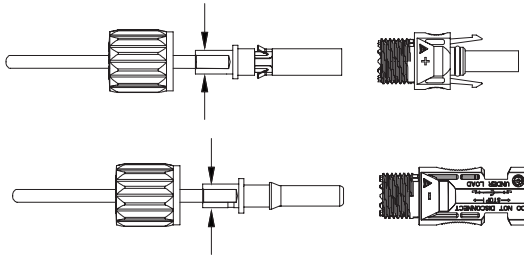

5. Use an open-end wrench to screw the nut to the end to ensure that the terminal is well sealed.

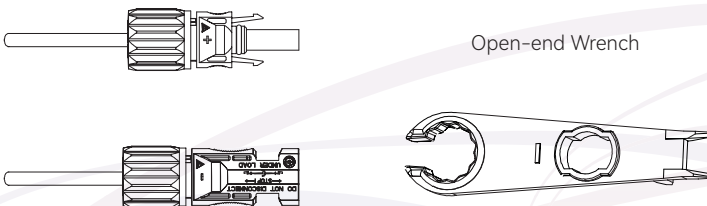



- ① Before connecting to the inverter, please make sure the polarity of the cable is correct.
- ② Use a multi-meter to measure the voltage of the battery pack and make sure that the voltage is within the inverter limitation and the polarity is correct.

6. Insert the positive and negative connector into the battery power terminals at both inverter side and battery side respectively. When you hear a “click” sound, it means that the connection is well and proper.

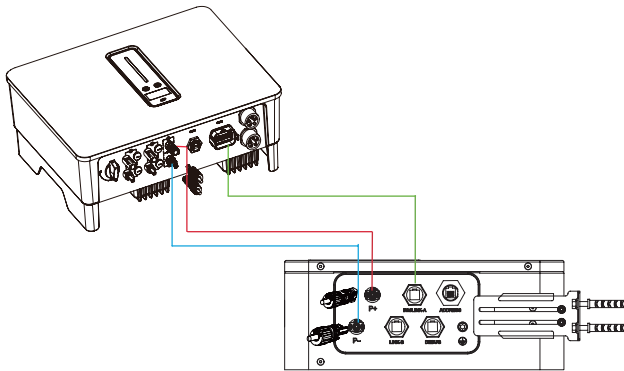

▼ 4.1.3 Communication Cable Connection

Please insert one side of the communication cable to the "INV/LINKA" port in the controller module, and the other side is connected to “BMS” port in Multi-com Connector at the inverter side.

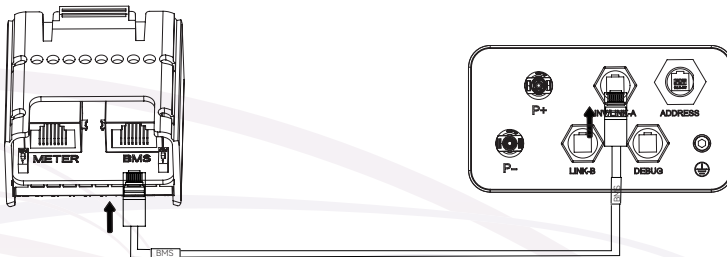

4.2 Multiple Battery Clusters with Paraller

The paraller supports at most three battery clusters to be parallel connected, which means the storage of whole battery system can reach 76.8kWh.

▼ 4.2.1 Electrical Wiring Diagram

After mechanical installation is finished, please follow the instructions to complete the power cable and communication cable connections.

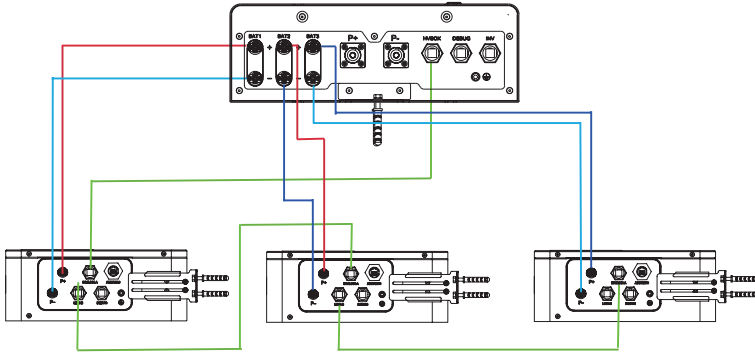

▼ 4.2.2 Power Cable Connection

Before starting connecting the power cable, please obey the following requirements to ensure personal safety:

- ① Turn the AC breaker off on the grid side.
- ② Turn both the battery breaker and paraller breaker off.
- ③ Switch the inverter DC switch to the “OFF” position.

Power cable connection between battery cluster and EBS-P procedure is shown as below:

1. Select an appropriate DC cable.

Cable requirements		Cable stripping length
Outside diameter	Conductor core section	
5.0-8.0 mm	10 mm ²	10 mm

2. Peel off the battery cable insulation sleeve for 10 mm.

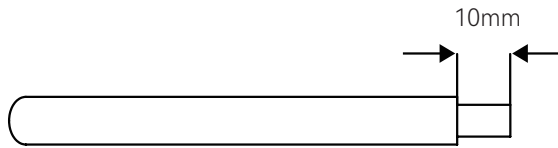

3. Take out the battery terminals in the accessory bag.

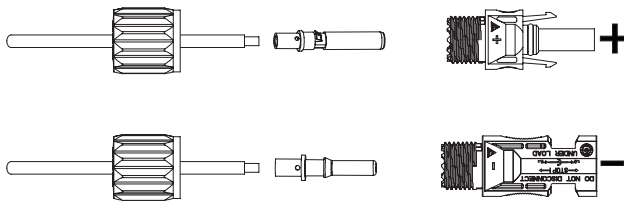

4. Insert the positive and negative cables into the corresponding connectors, and then press the terminal with crimping pliers. After assembling, try to pull back the battery cable to ensure that the terminal is tightly attached in the connector.

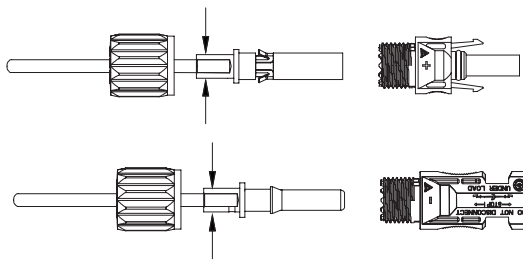

5. Use an open-end wrench to screw the nut to the end to ensure that the terminal is well sealed.

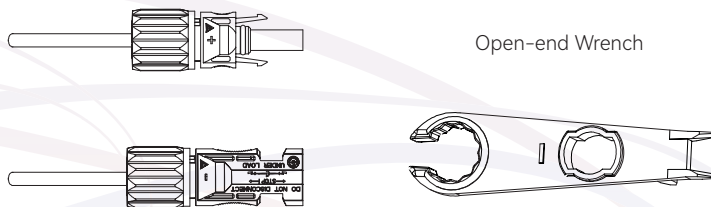

6. Insert the positive and negative connectors into the battery power terminals at EBS-P side one cluster by one cluster respectively. When you hear a “click” sound, it means that the connection is well and proper.

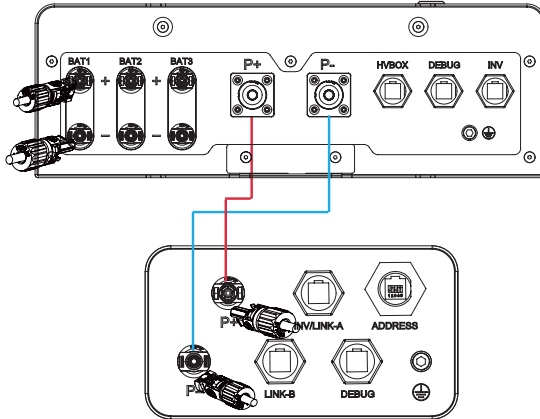

Power cable connection between EBS-P and the inverter procedure is shown as below:

1. Select an appropriate DC cable.

Cable requirements		Cable stripping length
Outside diameter	Conductor core section	
10.0-12.0mm	25-35 mm ²	20 mm

2. Peel off the battery cable insulation sleeve for 20 mm.



3. Take out the connectors in the accessory bag, and then thread the cable into end cap, grommet, and cable gland in turn.

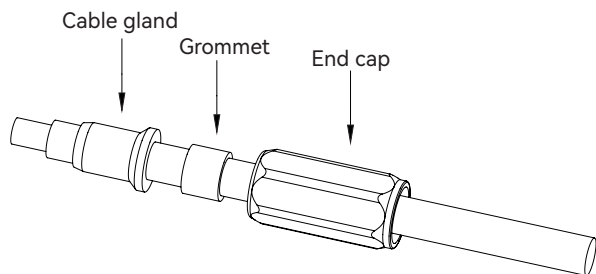

4. Insert the positive and negative cables into the corresponding connectors, and then press the terminal with crimping pliers. After assembling, try to pull back the battery cable to ensure that the terminal is tightly attached in the connector.

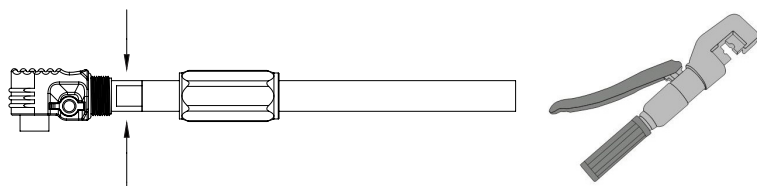

5. After crimping, push the cable gland, grommet and end cap at the plug end into place, and tighten the end cover with the thread of the plug unit.

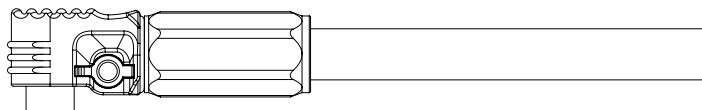

- ① Before connecting to the inverter, please make sure the polarity of the cable is correct.
- ② Use a multimeter to measure the voltage of battery system and make sure that the voltage is within the inverter limitation and the polarity is correct.

6. Insert the positive and negative connector into the battery power terminals at both inverter side and EBS-P side respectively. When you hear a “click” sound, it means that the connection is well and proper.

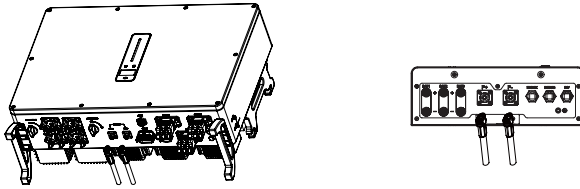

7. When pulling out the plug, you need to press the switch button first, and then pull the plug out.

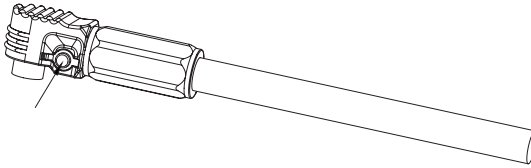

▼ 4.2.3 Communication Cable Connection

1. Please insert one side of the communication cable to the "INV" port at EBS-P, and the other side is connected to "BMS" port in Multi-com Connector at the inverter side.

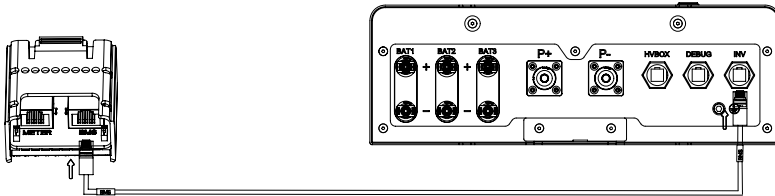

2. If a parallel is needed, the addresses of connected battery clusters must be modified to help the parallel recognize.

Set address 0 for the 1st battery cluster.

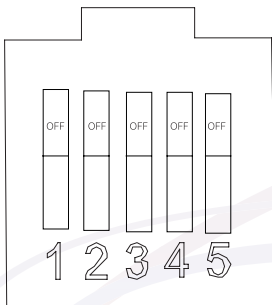

Address	DIP1	DIP2
0	OFF	OFF

Set address 1 for the 2nd battery cluster.

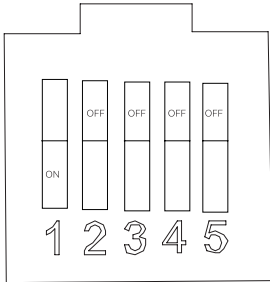

Address	DIP1	DIP2
1	ON	OFF

Set address 2 for the 3rd battery cluster.

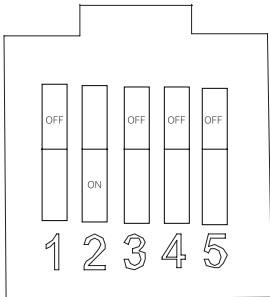

Address	DIP1	DIP2
2	OFF	ON

3. Turn DIP5 of the battery cluster connected to EBS-P to "ON" position.

If the 3rd battery cluster is connected to EBS-P, the address would be:

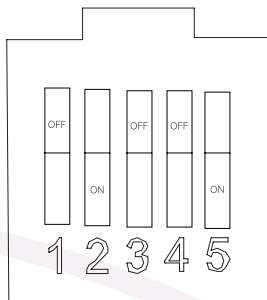

Address	DIP1	DIP2	DIP3	DIP4	DIP5
2	OFF	ON	OFF	OFF	ON

5 Commissioning

5.1 Switch Battery On

Step1. Turn the breaker on at the left side of controller module.

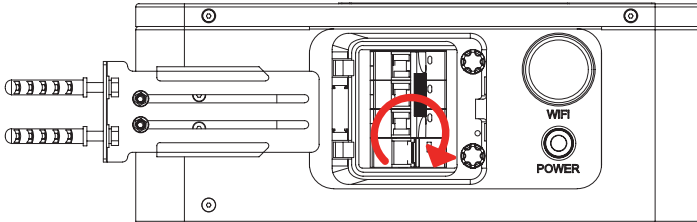

Step2. Hold down “POWER” button for 3 seconds until the indicator becomes green and flashing, which means that the battery enters self-checking.

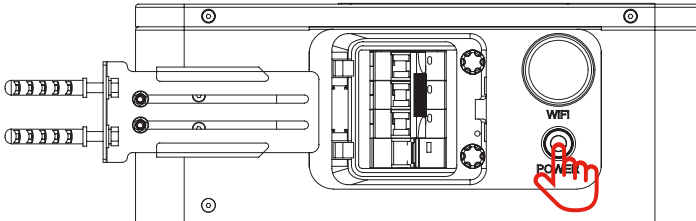

Step3. Wait for a while and check whether the indicator turns to be green and on or not.



NOTE

The steps above are only appropriate for battery startup. As for details about system startup, please refer to commissioning steps of the inverter user manual.

5.2 Switch Battery Off

Step1. Turn the inverter off (Refer to the inverter user manual for detailed procedure).

Step2. Hold down “POWER” button for 3 seconds until the indicator flashes green and red lights alternately.

Step3. Turn the breaker off at the left side of controller module.

6 Maintenance and Troubleshooting

6.1 Maintenance



Risk of battery damage or personal injury due to incorrect service!



Keep non-qualified persons away!

A temporary warning sign or barrier must be posted to keep non-qualified persons away while performing electrical connection and service work.



Restart the battery only when the trouble which might affect safety performance is cleared.

It is forbidden to random replace internal components.

For any maintenance support, please contact Solinteg. Otherwise, Solinteg shall not be held liable for any damage caused.



It is not suggested to maintain or repair the battery if you are in the absence of proper tools, test equipment or have not clearly and thoroughly understood the latest revision of the manual.

Methods of maintaining the electrical components are shown as below:

Item	Check Point	Method	Abnormal Condition	Solution
Voltage	Check whether the Out-putvoltage is normal.	Multi-meter	The battery voltage exceeds the allowed range.	Contact distribution or Solinteg
Fault	Check whether the indicator is green and on.	Visual	The indicator turns to be red on or red flashing.	
Cable	Insulation, terminal	Inspection	Insulation crack,aging. The terminal is peeling or corroded.	Replace the cable or terminal

Battery module maintenance is shown as below:

Frequency	Item	Solution
Every month	Working environment	Keep away from heat sources and direct sunlight.
	Visual inspection	If there is damage, leakage or deformation, isolate the faulty battery pack, take photos and replace the battery.
Every quarter	Keep clean	Clean shell with cotton cloth. Be careful when cleaning.
	Connection status	Check each terminal for loose bolts and tighten again. Check the cable temperature.
Half a year	Measure and record voltage	Collect discharge data at least once every six months in the first year. In the second year, discharge data is suggested to be collected every three months. Check the historical records through DEBUG port. The alarm information shows that the battery is frequently overcharged, which means the battery has reached the charging and discharging protection point, and the capacity has not reached rated capacity. It is recommended to replace the battery immediately.

6.2 Troubleshooting

If any battery fault occurs, record the fault information, and switch the battery off according to the procedures in “5. Commissioning”, and then contact the distributor or Solinteg. Do not handle the fault by yourself.

No.	Trouble	Reason	Solution
1		The voltage of this battery cluster is smaller than 80V.	One battery cluster must be equipped with at least 2 battery modules, and single cell voltage should be greater than 2.5V.
2	The indicator is off when the breaker is switched on	When single cell voltage drops to smaller than 2.5V, it will trigger low voltage protection, which may lead the breaker to trip. Once the system does not supply the battery during 15 minutes after the breaker is switched on, the breaker will trip again.	Keep the grid and PV to supply the battery.
3		Controller internal fault or other faults	Please contact Solinteg.
4	The indicator only displays red on or red flashing when the battery is powered on.	The alarm, protection or fault is triggered.	The fault and its detailed information can be found on Solinteg platform.
5	“POWER” button is pressed after green and red lights are flashing alternately, but the light does not turn to flash green,	The time of pressing “POWER” button is less than 3s.	Restart the battery and press “POWER” button for more than 3s after green and red lights flash alternately.
6		“POWER” button is damaged.	If the action above is taken for multiple times and the issue is still not able to be solved, please replace “POWER” button.

7 Appendix

7.1 Technical Parameters

▼ 7.1.1 Components of EBS-B Storage System

Battery	EBS-B2K5-B
Nominal Energy (kWh)	2.56
Usable Energy (kWh)	2.3
Nominal Capacity (Ah)	50
Nominal Voltage (V)	51.2
Voltage Range (V)	44.8~57.6
Max. Charge/Discharge Current (A)	50 / 50
Weight (kg)	32
Dimension[W*D*H] (mm)	650*350*168 (with Positioner)
Operation Temperature (°C)	0~55 (Charge) / -10~55 (Discharge)
Relative humidity	5%~95% (No condensation)
Altitude (m)	2000
Cell Type	LiFePO4
Module Connection	Hard Connection with Positioner
Installation Method	Stackable
Module Number	2~10 in series
Communication	CAN with integrated socket

Controller	EBS-C
Operation Voltage [Vdc]	80 - 750
Max. Charge/Discharge Current [A]	50 / 50
Communication	CAN/RS232
Power Connection Type	Hard Connection with Positioner & Quick Connector
Dimension [W*D*H mm]	650*350*140
Weight [kg]	17
Operating Temperature [°C]	-10~55
Relative humidity	5%-95% (No condensation)
Altitude (m)	2000

Paraller	EBS-P-B
Operation Voltage [Vdc]	100 - 1000
Max. Charge/Discharge Current [A]	150
Communication	CAN/RS232
Power Connection Type	Quick Connector
Dimension [W*D*H mm]	400*136*343
Weight [kg]	6
Operating Temperature [°C]	-10~55
Relative humidity	5%-95% (No condensation)
Altitude (m)	2000

Base	EBS-A
Operation Voltage [Vdc]	80 - 750
Max. Charge/Discharge Current [A]	50 / 50
Dimension [W*D*H mm]	650*350*118 (with Positioner)
Weight [kg]	12
Operating Temperature [°C]	-10~55
Relative humidity	5%-95% (No condensation)
Altitude (m)	2000

▼ 7.1.2 Energy Storage System

Storage System	EBS-S5K1-B	EBS-S7K5-B	EBS-S10K-B
Nominal Energy (kWh)	5.12	7.68	10.24
Usable Energy (kWh)	4.61	6.91	9.22
Nominal Capacity (Ah)	50	50	50
Nominal Voltage (V)	102.4	153.6	204.8
Voltage Range (V)	89.6 - 116.8	134.4 - 175.2	179.2 - 233.6
Recommend Charge/Discharge Current (A)	25 /25	25 /25	25 /25
Max. Charge/Discharge Current (A)	50 / 50	50 / 50	50 / 50
Weight (kg)	90	122	154
Dimension[W*D*H] (mm)	650*350*487	650*350*621	650*350*755
Protection Degree	IP54		
Warranty	10 years (Performance warranty)		
Operation Temperature (°C)	0~55 (Charge) / -10~55 (Discharge)		
Relative humidity	5%-95% (No condensation)		
Altitude (m)	2000		
Cell Type	LiFePO4		
Module Connection	Series / Hard Connection with Positioner		
Installation Method	Stackable & max. 3 Clusters in Parallel		
Module Number	2	3	4
Communication	CAN with RJ45 Connector		
Certification	CE/IEC62619/UN38.3		

Storage System	EBS-S12K-B	EBS-S15K-B	EBS-S17K-B
Nominal Energy (kWh)	12.8	15.36	17.92
Usable Energy (kWh)	11.52	13.82	16.13
Nominal Capacity (Ah)	50	50	50
Nominal Voltage (V)	256	307.2	358.4
Voltage Range (V)	224 - 292	268.8 - 350.4	313.6 - 408.8
Recommend Charge/Discharge Current (A)	25 /25	25 /25	25 /25
Max. Charge/Discharge Current (A)	50 / 50	50 / 50	50 / 50
Weight (kg)	186	218	250
Dimension[W*D*H] (mm)	650*350*889	650*350*1023	650*350*1157
Protection Degree	IP54		
Warranty	10 years (Performance warranty)		
Operation Temperature (°C)	0~55 (Charge) / -10~55 (Discharge)		
Relative humidity	5%-95% (No condensation)		
Altitude (m)	2000		
Cell Type	LiFePO4		
Module Connection	Series / Hard Connection with Positioner		
Installation Method	Stackable & max. 3 Clusters in Parallel		
Module Number	5	6	7
Communication	CAN with RJ45 Connector		
Certification	CE/IEC62619/UN38.3		

Storage System	EBS-S20K-B	EBS-S23K-B	EBS-S25K-B
Nominal Energy (kWh)	20.48	23.04	25.6
Usable Energy (kWh)	18.43	20.74	23.04
Nominal Capacity (Ah)	50	50	50
Nominal Voltage (V)	409.6	460.8	512
Voltage Range (V)	358.4 - 467.2	403.2 - 525.6	448 - 584
Recommend Charge/Discharge Current (A)	25 /25	25 /25	25 /25
Max. Charge/Discharge Current (A)	50 / 50	50 / 50	50 / 50
Weight (kg)	282	314	346
Dimension[W*D*H] (mm)	650*350*1291	650*350*1425	650*350*1559
Protection Degree	IP54		
Warranty	10 years (Performance warranty)		
Operation Temperature (°C)	0~55 (Charge) / -10~55 (Discharge)		
Relative humidity	5%-95% (No condensation)		
Altitude (m)	2000		
Cell Type	LiFePO4		
Module Connection	Series / Hard Connection with Positioner		
Installation Method	Stackable & max. 3 Clusters in Parallel		
Module Number	8	9	10
Communication	CAN with RJ45 Connector		
Certification	CE/IEC62619/UN38.3		

7.2 Contact Information

Should you have any question about this product, please contact us.

We need the following information to provide you the best assistance:

- Model of the device
- Serial number of the device
- Date of the device
- Fault code/name
- Brief description of the problem

China (HQ)

Solinteg Power Co., Ltd.

Address: Building H1-1001, No. 6 Jingxian Road, Xinwu District, 214135 Wuxi, Jiangsu Province, China

Website: www.solinteg.com

Service Mail: service@solinteg.com

INTEGRATE SOLAR INTELLIGENTLY



www.solinteg.com